



**GUIDE BLOCK KIT  
PACE P/N 6993-0105-P1  
FOR USE ON CT-15 ConductTweez® & TW-15 ResisTweez® Handpieces  
INSTALLATION INSTRUCTIONS  
MANUAL NUMBER 5050-0202 REV. D**

The enclosed PACE Guide Block Kit (P/N 6993-0105) is used on CT-15 ConductTweez and TW-15 ResisTweez handpieces only. Install the kit using the following procedure and illustration to obtain optimum results.

**CAUTION**

Insure that the handpiece is at room temperature before installing the Guide Block Kit.

1. Loosen the Tip Retaining Screws and remove any installed Tip(s) from the Tip Holders.
2. Referring to the illustration, remove the one Tip Retaining Screw pictured closest to the Guide Block Screw.
3. Slide the Guide Block over Tip Holders with the tapered edge toward the handpiece. The Guide Block Screw must be on the outside edge of the Tip Holder. Refer to the illustration for proper orientation of Guide Block.
4. Squeeze handpiece handles together. Position the Guide Block against the end of the handpiece as shown. Tighten Guide Block Screw to secure in position. Do **NOT** over tighten screw. Release the handpiece.
5. Open and close handpiece to check for free movement of Tip Holders. If any binding occurs, loosen Guide Block Screw, readjust Guide Block and tighten Guide Block Screw.
6. Install the Tip Retaining Screw removed in step 2. Do **NOT** tighten.
7. Install the Molded Stop in position as shown.
8. Install the Tip(s) in Tip Holders. Tighten Tip Retaining Screws to secure in position.
9. Check Tip(s) for proper alignment. Readjust Tip alignment as required.

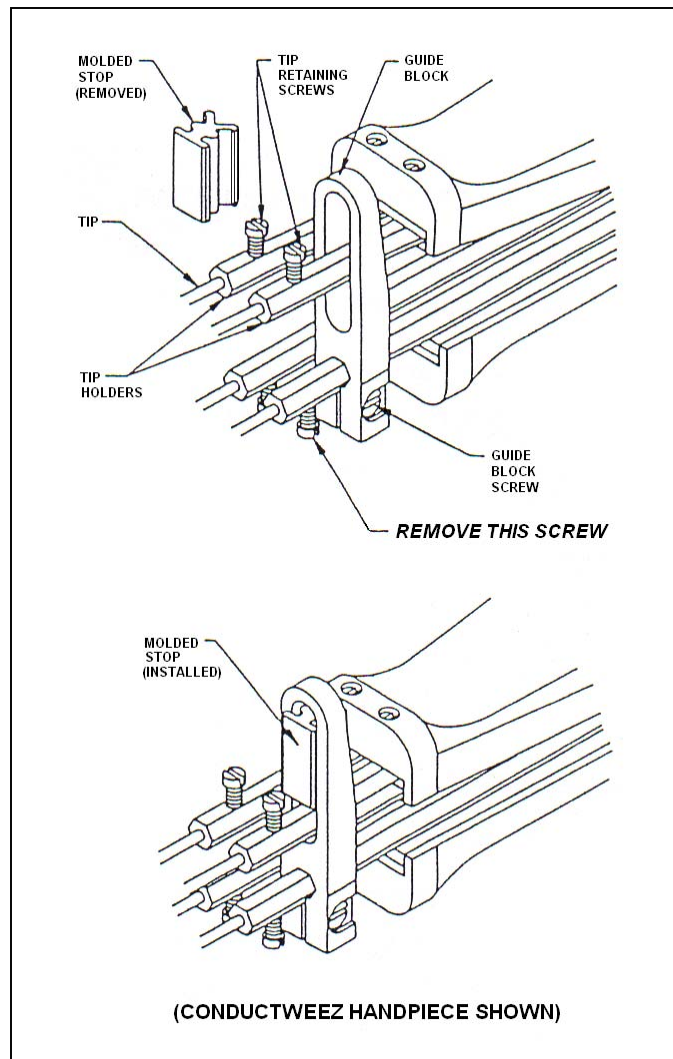

PACE Incorporated retains the right to make changes to specifications contained herein at any time, without notice. Contact your local authorized PACE Distributor or PACE Incorporated to obtain the latest specifications.

The following are trademarks and/or service marks of PACE, Incorporated, MD, USA:

INSTACAL™, FUMEFLO™, HEATWISE™, PACEWORLDWIDE™, PERMAGROUND™, POWERPORT™, POWERMODULE™, TEMPWISE™, TIP-BRITE™, AUTO-OFF™, and TEKLINK™.

The following are registered trademarks and/or service marks of PACE Incorporated, Annapolis Junction Maryland U.S.A.

ARM-EVAC®, FLO-D-SODR®, MINIWAVE®, PACE®, SENSATEMP®, SNAP-VAC®, SODRTEK®, SODR-X-TRACTOR®, ST 325®, THERMOJET®, THERMOTWEEZ®, VISIFILTER®, THERMO-DRIVE®, and TOOLNET®.

PACE products meet or exceed all applicable military and civilian EOS/ESD, temperature stability and other specifications including MIL STD 2000, ANSI/JSTD 001, IPC7711, and IPC A-610.

Additional copies of this manual or other PACE literature may be obtained from:



**PACE Incorporated**  
 9030 Junction Drive  
 Annapolis Junction,  
 MD 20701  
 Tel: (301) 490-9860  
 Fax: (301) 498-3252

**PACE Europe Limited**  
 13 Tanners Drive  
 Blakelands  
 Milton Keynes  
 Tel: (44) 1908-277666  
 Fax: (44) 1908-277777